

UM-LM08 Manual Barcode Reader



Table of Contents

1.0 INTRODUCTION	3
2.0 FUNDAMENTALS	5
2.1 <i>Barcodes</i>	5
2.2 <i>UPC Standard</i>	5
2.2.1 UPC A	5
2.2.2 UPC E Symbol	6
2.3 <i>EAN Standard</i>	7
2.3.1 EAN 13 Symbol	7
2.3.2 EAN 8	7
2.3.3 ISBN Symbol	8
2.4 <i>Codabar</i>	9
2.5 <i>Code 39</i>	9
2.6 <i>Code 39 Extended</i>	9
2.7 <i>Code 93</i>	9
2.8 <i>Code 128 and UCC / EAN 128</i>	10
3.0 DETECTION OF BARCODES	11
3.1 <i>Gaussian beams</i>	11
3.2 <i>Light scattering</i>	13
3.3 <i>Signal evaluation</i>	14
4.0 EXPERIMENTAL SET-UP	14
4.1 <i>Description of Components</i>	15
4.1.1 Barcode Scanner	15
4.1.2 Scanner Interface ED-0270	17
5.0 MEASUREMENTS	18
5.1 <i>Preparing the Scanner</i>	18
5.1.1 Photodetector Signals	19
5.1.2 Repetition rate	20
6.0 SOFTWARE	21
6.1 <i>Installing the software and related driver</i>	21
6.1.1 USB driver	21
6.2 <i>Installing the Bar Code Software</i>	21
6.2.1 Database	22
6.2.2 Program Menus	23
6.2.3 Generation of Barcodes	23
6.2.4 Reading the Barcodes	23
6.2.5 Printing the Barcode Labels	23
6.2.6 Changing the Password	23

1.0 Introduction

The invention and the application for identifying products of all kinds with the help of bar code technology is one of the most important developments of our century. Those, who have had to wait for long hours at the cash counter of a super market, because the bar code reading system has broken down, can imagine this. However, the impetus for developing this technique did not come from the desire to offer the customers a special service, but instead to make the supermarket more profitable.

The existence of the supermarkets can be traced back to the colonisation of North America. Small business concerns during this time specialised in everything that was needed for a new start. It is, therefore, no wonder that the barcode technique was invented and developed in this country.

When the concept of the supermarkets was introduced in the big cities, naturally a competition arose, which aimed at attracting the customers with the best possible prices. This again required that the undertaking still remained profitable. The boss of the supermarket had to know exactly the goods that were leaving his company, to make arrangements for the supplies on the one hand and to avoid the dead stocks on the other. For this purpose, his market had to be closed down at least once a month for stock-taking.

Long before the bar code was invented, the businessmen knew that such a thing was required urgently. The first step in this direction was taken in 1948, when Bernard Silver overheard by a chance a conversation between the President of a chain of grocery stores and the director of the Philadelphia's Drexel Institute of technology. In this conversation the President requested the Director to develop a technique, which made it possible to manage the goods traffic in supermarkets much easier than a monthly stock taking. However, the director turned down the request, probably because the subject was to mundane for him.

When B. Silver talked to his 27-year old friend Norman Joseph Woodland about this conversation, he became very enthusiastic about it. In one of the first experiments they used ink, which fluoresced very strongly under the influence of ultraviolet light. Although the process worked, the long-term stability of the ink was not satisfactory and the printing of the labels was too expensive. But Woodland was convinced of his idea. He resigned from his work at the Drexel Institute of Technology, gathered all his savings and shifted to the apartment of his grandfather in Florida, in order to think more about this problem there. He found the solution after a few months, and the linear bar code was born. Woodland made use of the technologies already available, namely the sound film and the Morse code. He simply transformed the dash-dot arrangement of the code into vertical bars:

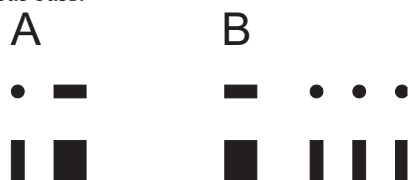

Fig. 1: Morse- and barcode

For reading the arrangement he made use of the idea of Lee de Forest's technique of the year 1920, in which the sound track of a film was recorded as a transmission on the border of the film strip as variations in the frequency of the sound. While playing the film, the changes of the transmission generated electrical currents with the help of an illumination and a photodetector, which after amplification, were passed on to the loudspeakers.

Woodland was, however, dependent on the reflection or scattering of the light for reading his printed bar code.

With this idea in mind, he went back to the Drexel Institute of Technology for formulating the patent together with his friend Silver, which they submitted on 20 October 1949. Silver modified the linear code to a concentric one for making the reading easier from all the directions.

In 1951 Woodland approached IBM with the hope of realising his ideas in a better way here. Together with Silver he made the first prototype in his New York apartment, which was about the size of a writing table. They used a 500 Watt light bulb as the source of light and as detector the photodetector 925 by RCA, which had been used in the sound film technology. An oscilloscope displayed the signal of the detector. Both the inventors could actually read a bar code. However, the same got damaged under the influence of strong light radiation. Moreover, they had to cover the whole apparatus with black cloth in order to suppress the outside light.

However, they were able to demonstrate the basic functioning of their device and got the patent in 1952.

They were still very far from an actual application, because it was still not possible to process the signals further with the help of a computer. Woodland was able to convince IBM to depute an expert to estimate the potential of their invention. The expert recognised the potential and also the problem, that this technique was about five years before its time. IBM tried many times to buy the patent from Woodland for a meager sum, but could not do it. Woodland sold the patent to Philco in 1962, who later sold it to RCA.

Many more pushes were needed before the bar code technique could enter business and industry. A clear impetus came from the railway industry, which was being operated by a number of private owners in North America. The freight cars of different companies were running on the tracks and it could be easily understood that it was a very demanding task to determine and follow up the current status in such a big network.

Around 1960 the Sylvania Corporation was on the look out for applications for its newly developed computer. For this purpose it engaged David J. Collins, who had worked on this subject during his studies with the Pennsylvania Railroad. Collins developed a bar code comprising of elements reflecting orange and blue. When the rail cars marked with this bar code entered the station, they could be registered with the help of flashlights and photodetector and the computer could do the rest. By 1967 Collins had advanced so much with his work, that he suggested the company to develop devices, which could read and evaluate the black-white bar code of Woodland, since he perceived a huge market here. Sylvania Corporation did not see this and Collins went and established his own company, the *Computer Identics Corporation*.

At this time the Helium Neon Laser were available at economical prices, with the help of which Collins developed his first bar code reading devices for the industry. A source of light was now available, whose thin beam could scan the bar code labels with the help of a rotating mirror. However, the decisive push for a breakthrough came from the grocery industry, which formed a committee to study the technical introduction of the bar codes of Woodland and Collins and its standardisation. RCA, which possessed the patent of Woodland and Silver, propagated the concentric bar code pattern. IBM now perceived big business and remembered that Woodland was once in its employ. He was immediately re-called into a team, which worked on developing a better pattern. IBM decided on a linear pattern. An eighteen-month long field test was carried out. The linear pattern of IBM proved to be superior, since the concentric patterns normally got smeared during printing, which made a proper reading of the code impossible. The linear pattern could be arranged during printing in such a way, that the smear got directed in the direction of the code and hence did not influence the reading process.

The code suggested by IBM was officially introduced in USA as the Universal Product Code (UPC) on April 3, 1973. The huge investments related with this made even the Pentagon pale in the face. US\$ 5.200.000 alone was proposed for buying the new devices for the thousands of super markets. The annual printing costs of the bar code labels were estimated to be a whopping 200 Million. Apart from this, the chain of stores needed separate computing centres (which naturally pleased IBM). A gigantic volume of investments was not only planned, but also spent. According to initial estimates, the investments would pay off within 2-3 years.

The other regions of the world also showed interest in this system. A slightly modified UPC code was introduced in Europe in December 1976 called the European Article Numbering Code (EAN). It is difficult to imagine the huge investments done all over the world for introducing the bar code. Apart from the super markets, all the organizations concerned with the management and distribution of goods also started working with bar codes. This included the industry, the complete book industry with the ISBN code, the pharmaceutical industry, hospitals and libraries, just to name a few.

The next time when you now go to the departmental store and stand at the cash counter, you would view the strange device, which takes money out of your pocket with a beep, in a different way. Maybe you would also think what would happen, if all these devices broke down. However, once you have finished the project "XP27 Barcode Reader", your trust in this exciting technology would make you forget the rare breakdowns. One thing remains: Each beep costs you money, when you are in the supermarket and it is your turn to pay.

2.0 Fundamentals

This chapter will discuss the symbols, the coding and the optical-electronic determination of the bar code.

2.1 Barcodes

Different kinds of bar codes have been developed during the course of time. They are different, corresponding to the requirements to the different user groups. The UPC code became established in the USA for trade and for the supermarkets. Based on this code, the EAN code was introduced in Europe. Both the types are meant to be used mainly in the supermarkets. The disadvantage of this code for other areas of economy is that firstly only numbers are permitted and secondly the length of the code is fixed. Hence, a special code was developed for libraries, which can also represent alphanumeric characters. At first the Codabar was developed for these codes, which initially recognised only the special characters. The quick development of microcomputers also permitted more complex codes. The code 39 already includes all the capital letters and the code 93, based on code 39, contains even the regular alphabet. However, the barcode labels should not become very long, as otherwise very special laser scanners are required. As a result, one is always searching for code forms, which not only have the highest possible character reserve, but also the highest possible density of information. The developments in this direction are the codes UPC

2.2 UPC Standard

The Universal Product Code (UPC) was introduced in 1973 in USA and Canada and is even today the most important bar code in these countries. There are two sub-groups of this code – the UPC A and the UPC E. The latter is a shorter version and is used for products with smaller dimensions e.g. cigarette packets.

2.2.1 UPC A

Each bar code has two properties. One is the symbol and the other the coding. The properties of the symbol refer to the geometric arrangement of the information and that of coding on the decoding of the information. The UPC A symbol is divided into two halves. A “centre guard” has been inserted in the middle of the symbol. A start and a stop character (‘101’) are present at the start and the end of the symbol respectively. 6 characters each are present on the right and the left side of the symbol. The actual information is present as the arrangement of two strips (black) and two blank strips (white) each within 7 modules (Table 1).

The start- and the stop characters are coded as 101, whereby a logical 1 is assigned to a dark strip and a logical 0 to a bright strip. The Centre Guard is coded as 01010. The actual information comprises of 12 x 7 bits. The complete symbol thus consists of 95 bits or strips.

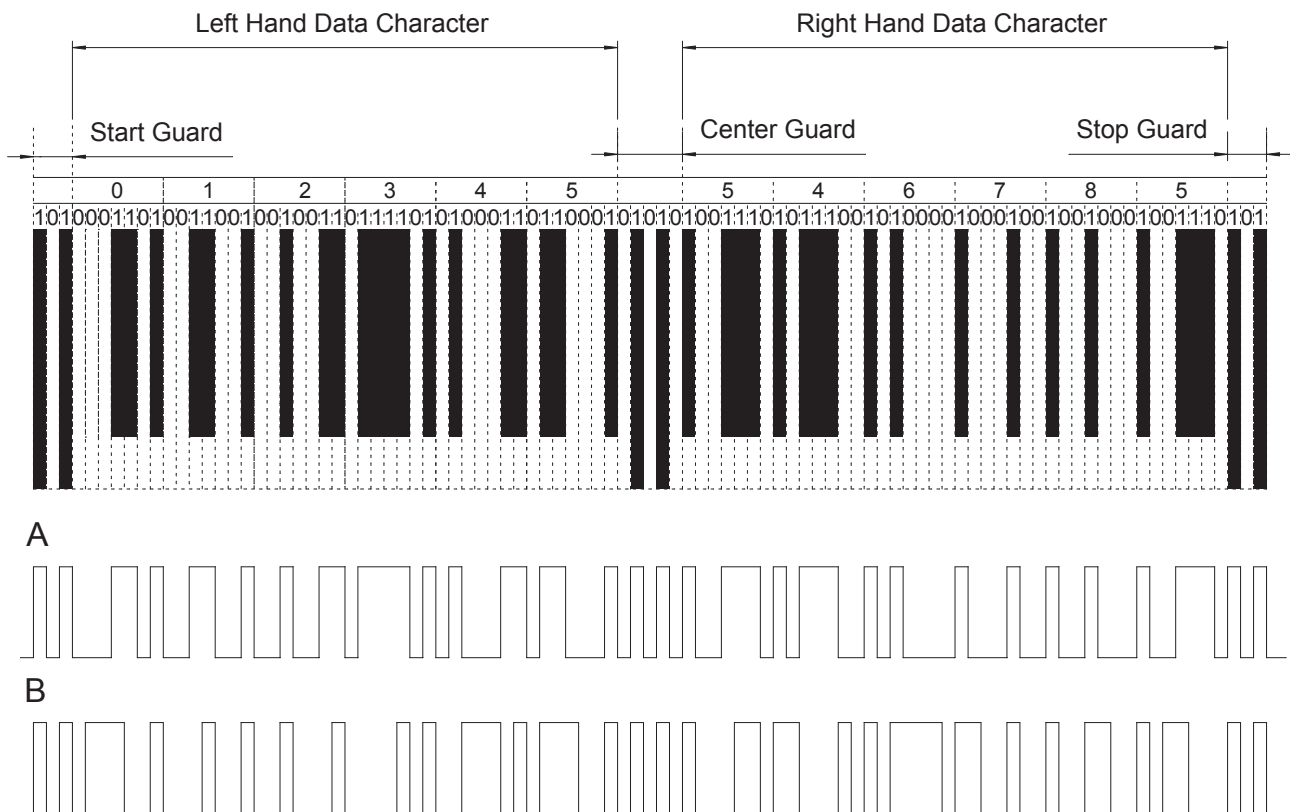

Fig. 2: UPC-A Code Structur “01234554678”

128 or EAN 128, which use control characters within the code for reducing the length of the bar code. These control characters send instructions to the processor of the bar code for converting the character set. There are also some relatively special codes, whose application area is relatively small. These exotic types will not be described here.

The character set A is used for the left side of the UPC-A symbol and the character set C for the right side (Table 1). In this way the scanner can determine the direction, in which the bar code was scanned. For this reason, the start- and the stop characters are identical. The purpose of these characters is only to inform the scanner about the width of the strip. The remaining strips are evaluated according to

this information. This increases the angular area, in which the bar code can be read.



Fig. 3: UPC - UPC-A Code with the information “01234554678” of the size SC5 (see Table 8)

The nominal width of a strip has been fixed at 13 mils. (1 mil corresponds to 1/1000 inch). For a strip number of 95 it amounts to a width of the complete symbol of 1.235 inch or 31.4 mm. Symbol widths of 25 to 62.8 mm are permissible for a permissible enlargement of 0.8 to 2.

	Character Set A					Character Set C				
0										
1										
2										
3										
4										
5										
6										
7										
8										
9										

Table 1: The character set A is used for the left half and the character set C for the right half of the UPC-A code

For a symbol to be decoded free of errors, the coded data set must contain a mechanism for a self-check. The check sum process, for example, represents such a process. For this purpose, a test number is calculated from the data set with a specific algorithm and is added to the symbol. A data set is uniquely valid only when the scanned data set and the newly calculated check number fit with each other. The 12th character in the UPC-A symbol contains this information. As a result, only 11 characters are available for the coding of the product.

1	2	3	4	5	6	7	8	9	10	11	
0	1	2	3	4	5	5	4	6	7	8	
0		6		12		15		18		24	75
	1		3		5		4		7		20
Sum =											95
Residual (95/10)											5
Check number =10-Residual											5

Table 2: Check sum calculation for the number 01234554678

One multiplies the characters present at odd places (1,3,5,7,9,11) with 3 and adds the results. One then determines the sum of the even places (0,2,4,6,8,10 without the check number at the 12th place!).

One then adds both these results and divides the number by ten. The difference of 10 – residual is then the check-sum:

$$10 - \text{residual}(95/10) = 5$$

In case any character is not read properly during scanning, the scanner then calculates a checksum, which does not conform to that at the twelfth place of the symbol. The result is thus not validated. Hence, the test number procedure cannot re-establish the original code. It can, in all probability, determine a reading error.

We now know, that the UPC-A symbol consists of 11 characters and a checksum. Each supplier and manufacturer, who have adopted the barcode procedure, has been assigned a unique number, so that no two manufacturers or suppliers issue duplicate data sets. The left data block (6 characters) contains the unique identification of the manufacturer of the product and the remaining 5 characters of the right side the unique product identification issued by the manufacturer. The first digit of the UPC-A code specifies the information encoded in the code:

0	Normal regular UPC Code
1	Reserved (for later use)
2	Products, which are paid by weight. Barcode is made in house
3	National Drug Code (NDC) and National Health Related Items Code (HRI).
4	UPC Code, which can be used without format restrictions
5	Coupon
6	Normal regular UPC Code
7	Normal regular UPC Code
8	Normal regular UPC Code
9	Reserved (for later use)

Table 3: Meaning of the first Characters

2.2.2UPC E Symbol

The UPC E symbol serves for identifying products with relatively small dimensions. The symbol comprises of eight characters, out of which the first is used for identifying the characters set used and the last for the check number. The start character consists of 2 and the stop character consists of 3 bars. A “Centre Guard” is not present

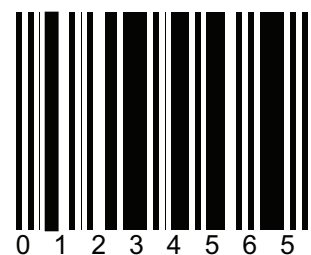

Fig. 4: UPC E symbol with the information “123456” and the size SC5

The character 0 is specified as the first character and implies that the first 3 characters are coded from the character set A and the remaining three of the data set from the character set B.

	Character Set A					Character Set B				
0										
1										
2										
3										
4										
5										
6										
7										
8										
9										

Table 4: Coding table for the EAN E Symbol

The check sum is calculated according to the same algorithm as in the case of UPC-A code.

2.3 EAN Standard

The “European Article Numbering” system is a further development of the UPC code for the European countries. It was introduced in 1978 and is at present the most widely used bar code system in the world. Apart from all the countries of the European Union, most of the other countries have also opted for this system.

2.3.1 EAN 13 Symbol

As the name already implies, the EAN-13 symbol comprises of 13 characters. The structure of the symbol is identical to that of the EAN-A. However, this symbol possesses one more character. The first 2-3 characters contain a country code (see Table 6). The next five identify the manufacturer of the product. Each country using the EAN code has a central issuing authority, which issues these characters. The next five characters are issued by the respective manufacturers and contain information about the product. The last character is meant to be a check number.

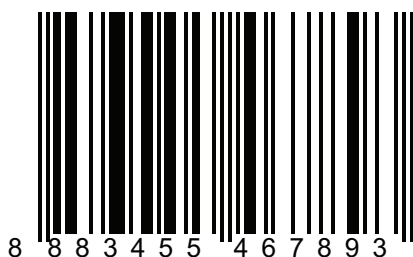

Fig. 5: EAN-13 Symbol with the information “888345546789” in the size SC5

The above code identifies a product from Singapore (888) and has the check number 3. According to a convention, the positions of the characters are numbered from left to right. This means, that the check number is present at position 1. The numbers at even places are multiplied by 3 and added up, whereas the numbers at odd places are only added up.

13	12	11	10	9	8	7	6	5	4	3	2	1
8	8	8	3	4	5	5	4	6	7	8	9	*
8		8		4		5		6		8		39
	24		9		15		12		21		27	108
												147
												Residual (147/10)
												7
												Check number=10-7
												3

Table 5: Check number calculation for the EAN Code

As per the international agreements, the positions of the characters are numbered from right to left. For this reason, the check number is present at the first position (*).

2.3.2 EAN 8

As in the case of the UPC symbols, there is a version that is suitable for smaller products. In contrast to the UPC-E symbol, this consists of only 8 characters.

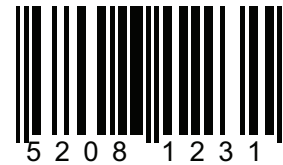

Fig. 6: EAN 8 Symbol of the size SC5

The first two or the first three characters identify the country of origin (Table 6), followed by four or five characters specifying the manufacturer and the product information. The first character (counted from right!) is the check number. The start- and the stop characters and the Centre Guard are present just as in the case of the EAN 13 Symbol. The check sum is calculated in the same way as for the EAN 13 Symbol.

Prefix	Country or use
00 - 13	U.S.A. & Canada (UCC)
20 - 29	In-store numbers
30 - 37	France (GENCOD EAN France)
380	Bulgaria (BCCI)
383	Slovenia (SANA)
385	Croatia (CRO EAN)
387	Bosnia Herzegovina (EAN BIH)
400 - 440	Germany (CCG)
45	Japan (Distribution Code Centre DCC)
460 - 469	Russian Federation (UNISCAN EAN Russia)
471	Taiwan (CAN)
474	EAN Estonia
475	EAN Latvia
477	EAN Lithuania
478	EAN Uzbekistan
479	EAN Sri Lanka
480	Philippines (PANC)
481	EAN Belarus
482	EAN Ukraine
484	EAN Moldova
485	EAN Armenia
486	EAN Georgia
487	EAN Kazakhstan
489	Hong Kong (HKANA)
49	Japan (Distribution Code Centre)
50	E Centre UK
520	Greece (HELLCAN EAN HELLAS)
528	EAN Lebanon
529	EAN Cyprus
531	FYR Macedonia (EAN MAC)
535	Malta (MANA)
539	EAN Ireland
54	Belgium & Luxembourg (ICODIF/EAN)
560	Portugal (CODIPOR)
569	EAN Iceland
57	EAN Denmark
590	EAN Poland
594	EAN Romania
599	Hungary (HAPMH)
600 - 601	EAN South Africa
609	EAN Mauritius
611	EAN Maroc
613	EAN Algeria
619	Tunisia (TUNICODE)
621	EAN Syria

Prefix	Country or use
622	EAN Egypt
625	EAN Jordan
626	EAN Iran
64	EAN Finland
690 – 693	China (Article Numbering Centre of China)
70	EAN Norge
729	EAN Israel
73	EAN Sweden
740	EAN Guatemala
741	EAN El Salvador
742	Honduras (ICCC)
743	EAN Nicaragua
744	EAN Costa Rica
745	EAN Panama
746	EAN Republica Dominica
750	Mexico (AMECE)
759	EAN Venezuela
76	EAN Schweiz, Suisse, Svizzera)
770	Colombia (IAC)
773	EAN Uruguay
775	EAN Peru
777	EAN Bolivia
779	EAN Argentina
780	EAN Chile
784	EAN Paraguay
786	Ecuador (ECOP)
789	EAN Brazil
80 - 83	Italy (INDICOD)
84	Spain (AECOC)
850	Cuba (CCRC)
858	EAN Slovakia
859	EAN Czech
860	Yugoslavia (EAN YU)
869	Turkey (UCCT)
87	EAN Nederland
880	South Korea (EAN Korea)
885	EAN Thailand
888	Singapore (SANC)
890	EAN India
893	EAN Vietnam
899	EAN Indonesia
90 - 91	EAN Austria
93	EAN Australia
94	EAN New Zealand
955	Malaysia (Malaysian Article Numbering Council)
977	Periodicals (ISSN)
978 to 979	Books (ISBN)
980	Refund receipts
981 - 982	Common Currency Coupons
99	Coupons

Table 6: Country- and use-prefixes for the EAN Code

In the following table shows the sizes of the barcode labels agreed upon:

SC Type	Scale factor	Field dimensions B x H i. mm
SC0	0.82	30.58 x 21.53
SC1	0.91	33.93 x 23.90
SC2	1.00	37.29 x 26.26
SC3	1.10	41.02 x 28.88
SC4	1.21	45.12 x 31.78
SC5	1.36	50.71 x 35.17
SC6	1.52	56.68 x 39.91
SC7	1.67	62.27 x 43.85
SC8	1.82	67.87 x 47.79
SC9	1.97	73.46 x 51.73

Table 7: Standard sizes for the EAN 13/UPC-A Barcode Labels

The field dimension is the dimension of the labels including a left margin of 11 and a right margin of 7 bars each of 13 mils. These free areas are also called as “quiet zones”. These zones are necessary to prevent an abrupt transition from the printed area of the product and enhance the readability. The dimensions of the zones are valid for an enlargement factor of 1 or for the type SC2.

SC-Type	Scale factor	Field Dimensions B x H i. mm
SC0	0.82	21.92 x 17.74
SC1	0.91	24.32 x 19.69
SC2	1.00	26.73 x 21.64
SC3	1.10	29.40 x 23.80
SC4	1.21	32.34 x 26.19
SC5	1.36	36.35 x 29.43
SC6	1.52	40.63 x 32.89
SC7	1.67	44.64 x 36.14
SC8	1.82	48.65 x 39.38
SC9	1.97	52.66 x 42.63

Table 8: Standard sizes of the EAN 8 Barcode Labels

In these labels the free right and the left zone has 7 bars 13 mils for the SC2 type (scale factor 1).

2.3.3 ISBN Symbol

A special form of the EAN 13 symbol is the ISBN Code (ISBN stands for *I*nternational *S*tandard *B*ook *N*umbering System). The first three characters are fixed at 978 or 979 (see also Table 6).



Fig. 7: ISBN Symbol with the information “091126109”

The ISBN check number is calculated according to Table 9. For this, the characters are multiplied with the factors of row 2 and then added up without the three-digit prefix (978). One now supplements the result as described above, so that it becomes divisible by 11 without any remainder. This supplement is then the ISBN check number. If the supplement is an even 10, an X must be set for the check number. The ISBN check number becomes 0 if the check-sum is divisible by 11 without remainder.

1	0	9	1	1	2	6	1	0	9	
2	10	9	8	7	6	5	4	3	2	
3	0	81	8	7	12	30	4	0	18	163
$160 / 11 = 14.54.. \Rightarrow 15 \cdot 11 - 160 = 5$										
ISBN Check number										5

Table 9: Calculating the ISBN check number

Since EAN 13 is the basis for the ISBN symbol, the check number comes out to be 7 in the above example according to its rules. Occasionally the UPC A and the EAN 13 Symbols are accompanied by the so-called “Add ON’s”. These are the symbols EAN 2 or EAN 5.



Fig. 8: EAN 2 und EAN 5 Symbols

These are, however, read by a reading device only together with a main symbol and contain, for example, information about the price.



Fig. 9: EAN 13 Symbol with EAN 5 Add On

The example given in Fig. 9 shows a combination of an EAN 13 symbol that starts with the number 29. In Table 6 this number has been determined as the identification of an ‘‘In-Store’’ product. This can be a product from the supermarket, whose price depends upon its weight and is determined before its sale. The additional symbol then contains the price as 01575, which is interpreted as USD 15.75. The additional symbols do not have any checksum and can be read only together with a main symbol.

2.4 Codabar

This code was developed in 1972 and is mainly used today in libraries, for identifying the blood samples and by some parcel services.

Codabar can represent 16 different characters, the numbers from 0-9 as well as \$, :, /, ., and the + character. The alphabets ABC and D are used as the start and the stop characters, so that the total number of characters becomes 20. The total length of the code is variable as compared to UPC-A/E and EAN 13/8.



Fig. 10: Codabar with B as start and A as stop bit.

0																							
1																							
2																							
3																							
4																							
5																							
6																							
7																							
8																							
9																							
-																							
\$																							
:																							
/																							
.																							
+																							

A																							
B																							
C																							
D																							

Table 10: Encoding of Codabar Symbols

The letter ABC and D can be used as the start and the stop bits. Each individual Codabar character is made up of 4 bars and three empty spaces between them. It is a self-testing code and for this reason does not contain a checksum.

2.5 Code 39

The Code 39 was the first alphanumeric code developed for the Barcode applications. The character set includes the numbers from 0 – 9, the 26 capital letters from A – Z as well as the special characters -, ., *, \$, /, + and %.



Fig. 11: Code 39 Symbol with the Information ‘‘CODE 39’’

Each character comprises of 5 bars and 4 blanks. Three elements are broad and 6 are narrow. This aspect enables a self-check of the code 39. A gap is present as a separation between the individual characters. The advantage of this code is its big character set. The disadvantage is the low density of information as well as a low tolerance. The * character is used as the start and the stop bit, which however, is not displayed always. The asterisks at the start and at the end of the text line are normally not printed. However, one sometimes finds the start/stop – asterisks in the text line. If, for example, *1234* is present in the text line, the useful information is only 1234, since the asterisks are an integral part of the Code 39 Symbol.

2.6 Code 39 Extended

This is an extended version of the Code 39 and can represent the ASCII – character set. The 26 small letters (a – z) as well as the special characters of the keyboard can also be represented with the help of the Code39 Extended.

2.7 Code 93

The Code 93 was introduced in 1982 as an extension of the code 39. The special thing about this code is its very high density. This also becomes clear in direct comparison with the Code 39 and Code 128.



Fig. 12: Code 39 Symbol



Fig. 13: Code 128



Fig. 14: Code 93

2.8 Code 128 and UCC / EAN 128

The Code 128 is an alphanumeric symbol and can represent the complete ASCII 128 character set with a very high information density. This code was introduced in 1981, but became popular for many applications only after 1990. Each character comprises of 11 bits that are arranged in such a way, that a sequence of three dark and three light bars arises for each character. The character set consists of 107 characters, four functional characters, 4 control characters for selecting the code set and three different start characters. Depending upon the start character the character set A, B or C is used for decoding:

- Code 128A** The capital letters and the special characters are coded in this character set.
- Code 128B** The capital- and small letters are contained in this character set.
- Code 128C** This character set has been optimised for representing numbers

The internationally acceptable symbol UCC / EAN 128 was developed based on the Code 128. The coding essentially corresponds to that of the Code 128, but a double start character is used. The EAN 128 has acquired a significant position for the goods logistics and a worldwide introduction of this symbol is anticipated. The immense advances made in the microprocessor technology permit a higher and more comprehensive data processing than what was possible at the time of the introduction of EAN 13 or the UPC E symbols. The motivation for introducing the codes at that time rested on a desire to improve the logistics within a supermarket. But today, the complete way from the manufacturer to the supermarket or to any other sale point. Additional information must be appended to the symbol in this case, which is necessary for the logistics and product designation. On the other hand is the information for the controlling authorities, which check the quality or the risk degree of the product. The EAN 128 symbols offer here the best possible conditions, since the code is able to use the control characters. A control character instructs the reading process to do the following decoding for carrying out a specific interpretation. These control characters are also called as data identifiers (DI)

Excerpt from the list of the current data identifiers (DI)		
17	Expiry date (YYMMDD)	n2 + n6
20	Product version	n2 + n2
21	Serial Number	n2 + an20
30	Quantity (No. of pieces contained)	n2 + an8
310(**)	Net weight in Kg	n4 + n6
314(**)	Area in square	n4 + n6
315(**)	Net volume in litres	n4 + n6
400	Order number of the	n3 + an30
410	“Delivered to”	n3 + n13
421	“Destination”, Pin code with 3-digit ISO country code	n3 + n13 + an9

(*) Position 1 = Length of the following data identifier, following places = length of the actual information.

(**) Position 4 = Indicator for the number of decimal places

n is used for numerical and an for alpha-numeric characters

A sample coding for a product with a net weight of 130.5 kg and a best-before date of 12.04.2002 will be:

3101130515020412

The characters in bold are the data identifiers.

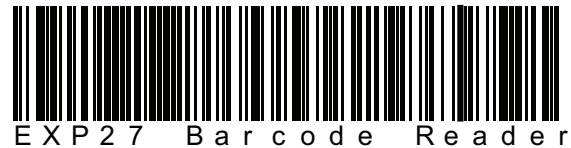

Fig. 15: Fig. 15 UCC / EAN 128 Symbol

Excerpt from the list of the current data identifiers (DI)		
DB	Coded data content	Format*
00	Number of the dispatching unit	n2 + n18
01	EAN of the business unit	n2 + n14
10	Batch number	n2 + an20
11	Date of manufacturing (YYMMDD)	n2 + n6
13	Packing date (YYMMDD)	n2 + n6
15	Best before date (YYMMDD)	n2 + n6

3.0 Detection of Barcodes

After discussing the barcode symbols and their coding in detail, we shall now move on to the optical-electronic reading of the symbols. The basic principle is shown in Fig. 16.

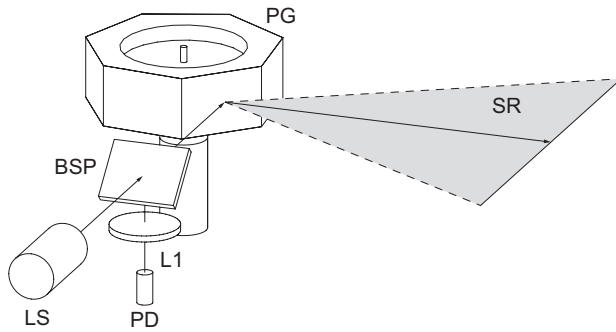

Fig. 16: Principle of a barcode scanner

The laser beam is deflected periodically by a rotating polygon mirror (PG). When the deflected light strikes a barcode symbol, it gets scattered. The intensity of the scattering depends upon, whether the light has struck a dark or a light bar. The main direction of scattering is opposite to that of the laser beam. The scattered light is transferred to the photo-detector (PD) through a translucent mirror (BSP) and the lens (L1). Here the changes in the intensity are converted in electrical signals and are then processed by a microprocessor. In order to have a high and efficient reading speed, the laser beam, the photo-detector and the contrast of the barcode must fulfil certain conditions. The next chapter describes how these conditions can be fulfilled.

3.1 Gaussian beams

Real parallel beams of light do not exist in reality and plain wave fronts are also present only at a specific point. The reason for the failure of the geometric optics is, that it arose at a time, when light was still not treated as an electromagnetic wave and that its behaviour could be described by Maxwell's equations:

$$\Delta \vec{E} - \frac{n^2}{c^2} \cdot \frac{\partial^2 \vec{E}}{\partial t^2} = 0$$

Without restrictions, light will propagate isotropic as a spherical wave in all the directions.

$$\vec{E} = \vec{E}(r) \text{ with } r^2 = x^2 + y^2 + z^2$$

However, for the case relevant to us, that the spherical wave propagates in a small solid angle in the direction z , so we have to define the boundary condition for the electrical field as:

$$\vec{E} = \vec{E}(r, z) \text{ whereby}$$

The solution of this modified wave equation gives electromagnetic fields, which have a Gaussian type distribution of intensity over the cross-section of the beam and are hence called Gaussian beams. Such beams, especially the Gaussian fundamental mode (TEM_{00}) is generated preferably by lasers. However, the intensity of a pure mode is very small as compared to the total intensity of the light source.

The situation is different in the case of lasers, where the complete light power can be generated in the base mode. Just like the monochromatic nature of the laser beam, this is one more outstanding difference to the conventional light sources. A Gaussian beam always possesses a "beam waist". The beam radius w (w stands for waist) gives the following from the solution of the above wave equation:

$$w(z) = w_0 \cdot \sqrt{1 + \left(\frac{z}{z_R}\right)^2}$$

Here the smallest beam radius is the waist w_0 and z_R the Rayleigh length.

$$z_R = w_0^2 \frac{\pi}{\lambda}$$

Fig. 17 shows the course of the beam diameter of a beam, which is propagating in the direction z . The beam has the smallest radius at the point $z = z_0$.

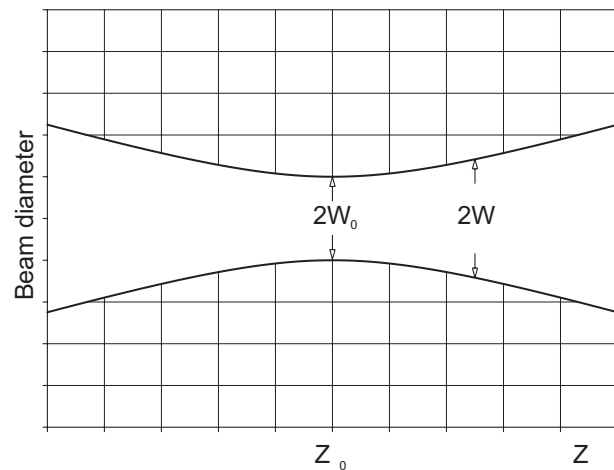

Fig. 17: Beam diameter of a Gaussian beam of fundamental mode TEM_{00} as function of the location z

The beam radius increases linearly with increasing distance. Since Gaussian beams are spherical waves, a radius of curvature of the wave field can also be assigned to each point z . The radius of curvature can be calculated from the following formula:

$$R(z) = z + \frac{z_r^2}{z}$$

This situation has been displayed in Fig. 18. At $z = z$ the radius of curvature is minimum. In the direction $z \rightarrow 0$ the radius of curvature increases like a hyperbola. At $z = 0$ the radius becomes infinite i.e. the wave front becomes plain here. Above the Rayleigh length $z > z_R$ the radius increases again linear. This is a very important statement. According to it, the beam is parallel only in one point i.e. in its focus.

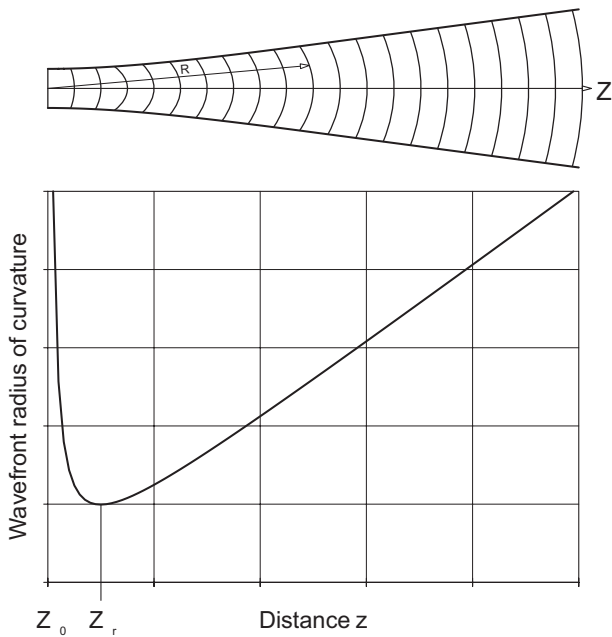

Fig. 18: Course of the radius of curvature of the wave front as a function of the distance of the beam waist at $z = 0$

In the range for

$$-z_r \leq z \leq z_r$$

a beam can be considered approximately to be parallel. The Rayleigh range has been shown in Fig. 19 as well as

the divergence Θ in the far field ($z \gg z_0$). The graphic representation shows, that the most excellent feature of the laser beam, namely its low divergence, cannot be represented in this way.

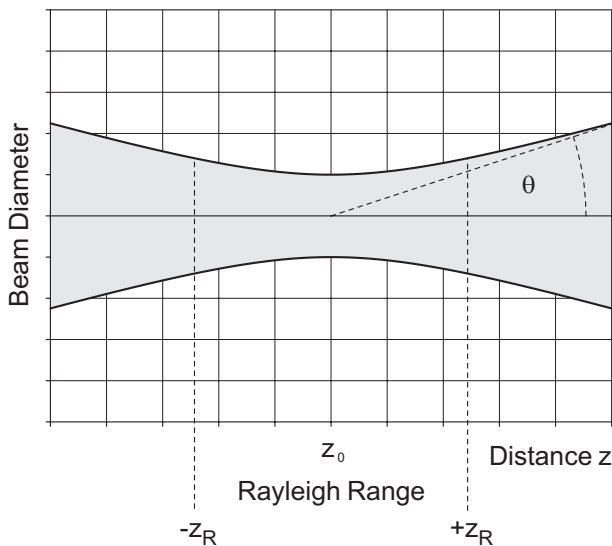

Fig. 19: Rayleigh range z_r and the far field divergence Θ

However, the reason for this is that the ratio of the beam diameter to z is not 1:1. As an example we take a HeNe-Laser

(632 nm) with a beam waist $w_0 = 1 \text{ mm}$ at the point of exit of the laser, we get the following value for the entire Rayleigh range

$$2 \cdot z_R = 2 \cdot w_0^2 \frac{\pi}{\lambda} = 2 \cdot 10^{-6} \frac{3.14}{623 \cdot 10^{-9}} = 9,9 \text{ m}$$

We can consider the laser beam to be parallel within this

length. After this the beam diameter increases corresponding to its divergence, which is determined by the divergence angle Θ . We can determine this angle from Fig. 19:

$$\tan \Theta = \frac{w_0}{z_r}$$

We are making use of the approximation here, that the laser beam can be treated as parallel in the Rayleigh range. If we use

$$z_R = w_0^2 \frac{\pi}{\lambda}$$

we finally get :

$$\tan \Theta = \frac{\lambda}{\pi \cdot w_0}$$

A commercial HeNe-Laser has a beam waist of approximately:

$$w_0 \approx 0.8 \text{ mm}$$

With the wavelength of 633 nm we calculate its divergence angle as:

$$\tan \Theta = \frac{633 \cdot 10^{-8}}{\pi \cdot 0.8 \cdot 10^{-3}} = 2.5 \cdot 10^{-3} \triangleq 2.5 \text{ mrad}$$

We have seen in chapter 2.2.1 that the nominal width of a bar of a symbol is 13 mils. The minimum permitted scaling factor is 0.8, so that the minimum width of a bar should be 10.4 mils or 0.026 mm. In order for the laser beam of the scanner to be able to differentiate between the bars, its diameter should not be higher than this value. In practice this means that the laser beam must not exceed this value within a specific distance from the scanner. The manufacturer of the scanner must manipulate the laser beam in such a way, that this condition is fulfilled. As already mentioned, a commercial HeNe-Laser has a beam diameter of 0.8 mm ($2w_0$) at the point of exit. The manufacturer must now with the help of a precisely calculated lens or lens system see to it, that the laser beam does not show a diameter greater than 0.02 mm ($2w$) over a distance b of, say, 50 cm.

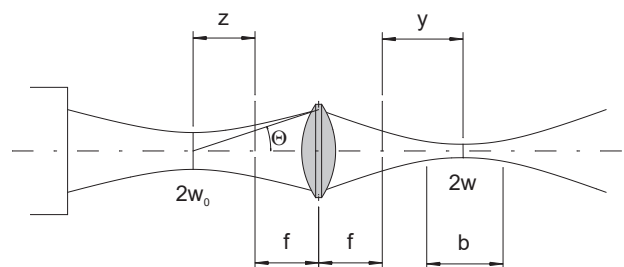

Fig. 20: For calculating the imaging optics

Beam waist radius:

$$w = \frac{w_0 \cdot f \cdot \theta}{\sqrt{w_0^2 + \theta^2 \cdot z^2}}$$

Location of beam waist

$$y = \frac{z \cdot f^2}{z^2 + \left(\frac{w_0}{\theta}\right)^2}$$

With the help of the equations given above, the necessary focal length f and the distance $z + f$ for the lens can be calculated. Hereby the range b must lie within the Rayleigh range.

3.2 Light scattering

When a laser beam strikes an optical surface, it gives rise to a scattering of light, which propagates in different directions of space depending upon the texture of the surface.

First, however, a description of the light scattered back by a destination object. There is no doubt that the intensity of the light scattered back depends on the texture of the destination object.

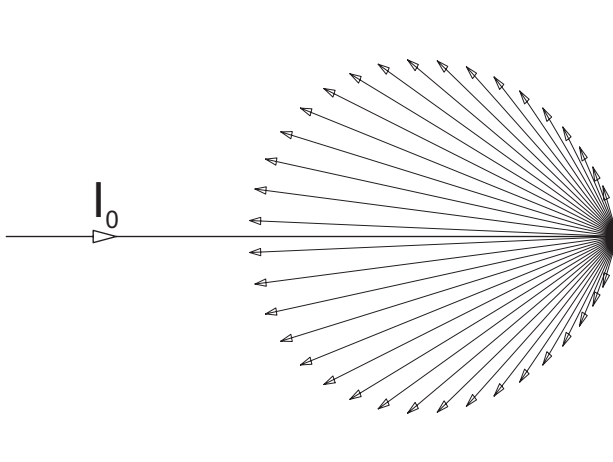

Fig. 21: Scattering of light at a surface

However, the scattering behaviour of many objects can be compared with that of the Lambert's bodies. Such a body emits received light as per the cosine distribution and it can also be called as a cosine radiator (Fig. 22).

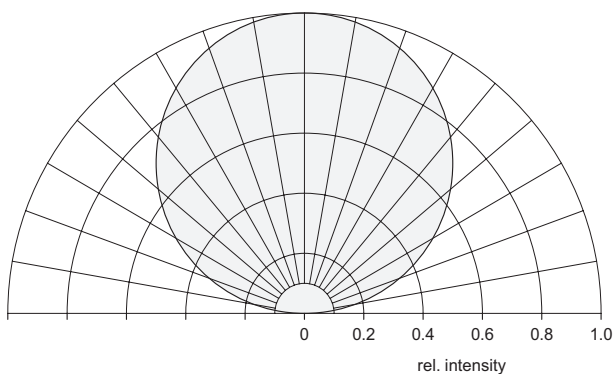

Fig. 22: Lambert's Cosine radiator

The main beam direction lies in the normal surface of the object. In reality the object distance L will be greater than the aperture diameter of the receiving optics. In this sense, the radiator can be considered as a spherical source, whose intensity decreases with the square of the distance and de-

pends on the cosine distribution. The light power, which finally reaches the photo detector, is the power that enters through the cross section of the receiving optics. In exact words this means that:

$$P = \beta \cdot P_0 \cdot \int_{d\Omega} \cos(\vartheta) \cdot d\Omega$$

The constant β characterizes the reflectivity of the object. In case of a sufficiently large distance, the lens gets only the light from the scattering object, which comes from an angular range of $\cos \vartheta \approx 1$. This simplifies the equation to:

$$P = \beta \cdot P_0 \cdot \int_{d\Omega} d\Omega = \beta \cdot P_0 \cdot \Delta\Omega$$

The size of the solid angle is given by the aperture angle of the receiving optics.

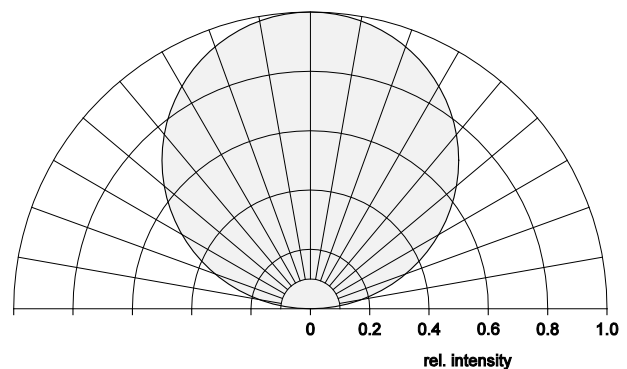

Fig. 23: Solid angle of receiver optics

The radiator (destination object) emits radiation only in a hemisphere, since it does not radiate backwards. The ratio of the spherical segment of the receiving optics to the surface of the hemisphere is directly proportional to the ratio of the power received to the power radiated:

$$\frac{2 \cdot \Delta\Omega}{\Omega} = \frac{F_{Optic}}{2 \cdot \pi \cdot L^2} = \frac{P}{\beta \cdot P_0}$$

or

$$P = \beta \cdot P_0 \cdot \frac{F_{Optic}}{2 \cdot \pi \cdot L^2} = \gamma \cdot P_0 \cdot \frac{r^2}{L^2} \text{ with } \gamma = \beta/2$$

The power received P reduces with the square of the distance L of the destination object and increases with increasing diameter r of the receiving optics. The distance L of the Barcode Symbol cannot be made small to any value, but instead only as per the requirements of the user. However, the effective diameter of the receiving optics can be optimised.

Ideally, the back-scattering coefficient for dark strips is 0 and is 1 for light strips.

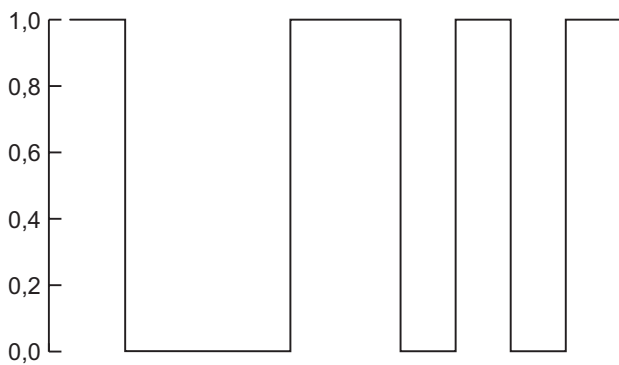

Fig. 24: Ideal back scattering

It is clear that this is not the case in reality. The decisive thing is that a sufficient contrast is present, so that the evaluating device can differentiate between dark and light bands. If we designate the light power received for a light bar with P_L and that for a dark bar with P_D , the contrast K becomes

$$K = \frac{P_L - P_D}{P_L} = \frac{\beta_L - \beta_D}{\beta_L}$$

Here .. the back-scattering coefficient is for the light surface of the barcode symbol and β_D is for the dark surface.

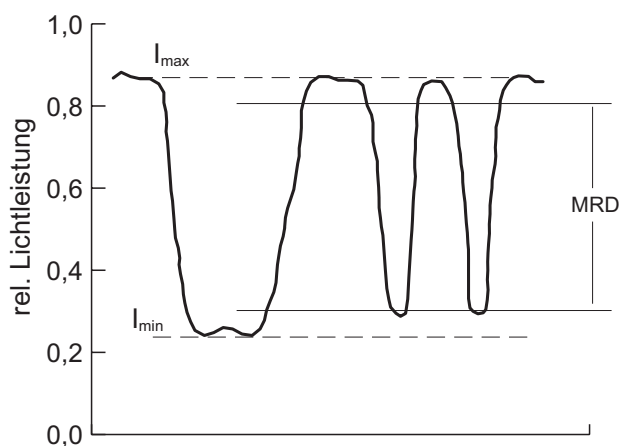

Fig. 25: Real back-scattering intensity

To have a uniform definition for the contrast and hence the minimum demands on the Barcode scanner, the term MRD (Minimum Reflectance Difference) was introduced. According to this, the MRD is 80% of the range

of $I_{\max} - I_{\min}$ (Fig. 25). The minimum MRD area should be 37.5% for Barcode symbols with a single bandwidth smaller than 40 mils and 20% for bandwidths equal to or greater than 40 mils. The manufacturers of the printers for barcode labels must adhere to this regulation. On this basis also the manufacturers of barcode scanners must design the signal evaluation electronics.

3.3 Signal evaluation

The signal evaluation of the Barcode Scanner can be broadly classified into three areas (Fig. 26).

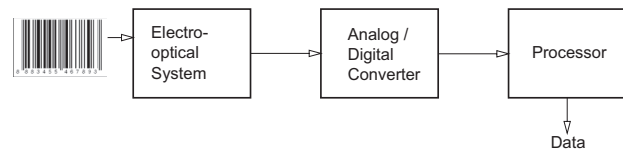

Fig. 26: Block diagram of signal evaluation

The electro-optical system converts the bright and dark transitions of the barcode signals into analogue voltages. In the subsequent Analogue-Digital converter these signals are converted in a digital form, which are then processed further by the processor. Basically the processor has to carry out the following steps:

1. Locating the start signal. The digital data are stored at first in a buffer. The processor checks, whether the first characters correspond to a known start code.
2. Determining the width of each bar. If the start code is recognized, the processor can then calculate the width of the remaining bars.
3. The code can now be determined from the width of the data elements. The code 39 makes use of two different widths and EAN four different widths.
4. It must now be checked, whether all the data is consistent with the determined code. If this is the case, the data is then compared with a stored table and decoded.
5. The direction of evaluation must be reversed, if necessary.
6. It is then checked, whether the prescribed length of the "quiet zone" is present at both the ends of the symbol.
7. In the last step it is checked, whether the check numbers, if available, conform to the read contents. The data set is printed, if all these criteria are fulfilled.

4.0 Experimental set-up

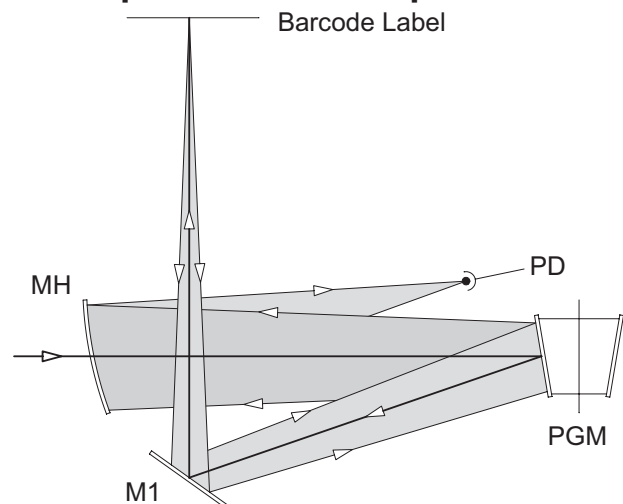

Fig. 27: Principle of the Barcode Scanner

The laser beam reaches the rotating mirror PGM (Fig. 27) through a hole in the spherical mirror MH. From here the laser beam is deflected to the barcode label by the deflecting mirror MI. The light scattered back reaches the hollow mirror MH through the deflecting mirror MI and the rotating mirror PGM. The hollow mirror focuses the light on the photo receiver PD. In this arrangement, only one track is created for reading the barcode label. But since the barcode can be read from many directions, many more laser tracks are necessary. This can be done by the arrangement shown in Fig. 28.

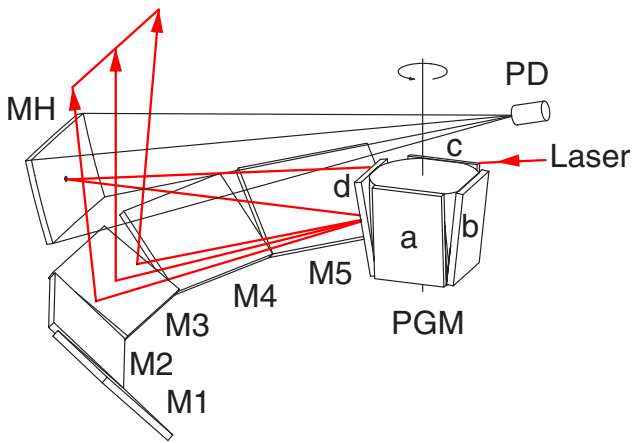

Fig. 28: Real arrangement with multiple mirrors

The laser beam reaches the rotating mirror PGM through a small bending mirror the mirror MH. However, each mirror (a, b, c, d) has a different inclination and five deflecting mirrors are used (M1 to M5) instead of only one. If the mirror arrangement rotates in the clockwise direction, the mirror 'a' will become the first one to be struck by the laser beam, and the first tracks to be created are M1a, M2a, M3a, M4a and M5a. The mirror 'b' creates the tracks M1b, M2b, M3b, M4b and M5b and so on. The pattern that thus emerges has been shown in Fig. 29.

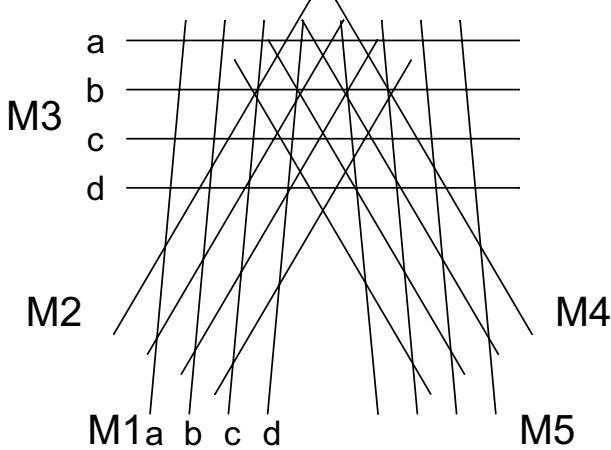

Fig. 29: Multiple Laser Tracks

Since the rotational speed of the mirror arrangement PGM is higher than the resolution power of our eyes, the tracks appear to us as lines. Actually only one laser point is moving along this path. From each point the scattered light is led to the photo detector PD through the hollow mirror MH. This converts the light-dark information in electrical signals.

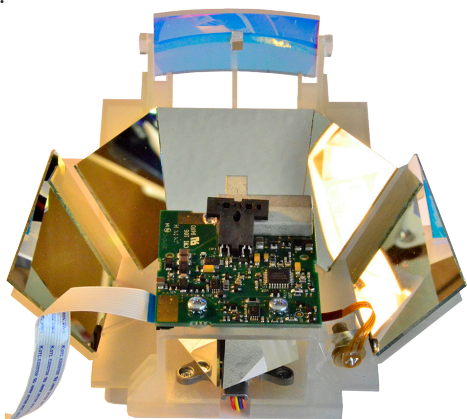

Fig. 30: Scanner engine

4.1 Description of Components

This section will describe and discuss the testing structure along with the components used.

4.1.1 Barcode Scanner

The bar code scanner is a professional device made by Metrologic Model Horizon 7625, which has been modified, for getting an access to the electrical signals.

The scan area is 203 x 203 mm with a height of 165 mm, measured from the upper edge of the device. Within this area a network of tracks is created as per the pattern shown in Fig. 29. The barcode label is scanned at a rate of 2000 lines per second. The measured values are interpreted and validated by a built-in microprocessor. The scanner can be programmed for different tasks. The programming is done through the barcode symbols, which have been explained in the accompanying handbook. The "default settings" are the best for within the experiment and also for the normal use and an additional programming of the scanner is necessary to fulfil one certain aspect. The scanner recognises the symbol as well as the decoded information of the barcode.



Fig. 31: Barcode Scanner Model Horizon MS 7625

To avoid additional symbol recognition by the software the scanner will be programmed in such a way that it sends also the symbol information to the PC. In the default configuration the scanner does not send this information. The programming of the scanner is done by scanning some special barcode labels.



Fig. 32: Recall Defaults

After that the following barcode will be scanned:



Fig. 33: Enable USB port communication

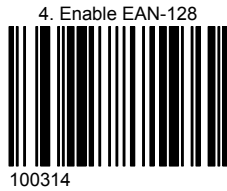

Fig. 34: Enable EAN 128 code

This setting adds a prefix to the transmitted characters to enable the software to detect the EAN 128 encoding.



Fig. 35: Enables sending of LF (Line Feed)

This setting adds the line feed character (LF) to each scan allowing the software to detect the end of the transmission.



Fig. 36: Transmit UPC E Check Digit

In the default configuration the scanner does not send the UPC E check number or digit. To enable this option the above barcode label should be scanned.



Fig. 37: Transmit Code 39 Start / Stop Character

The start and stop character of the Code39 Symbol is the asterisk (*) which is normally neither displayed nor transmitted from the scanner. To recognise this symbol, the software of the PC is looking for an asterisk at the beginning and the end of the transmitted code. Finally it has to be checked that between both asterisks the code consists of numbers only, otherwise it could also be an ASCII character code like EAN 128 etc. containing asterisks.



Fig. 38: Transmit Codabar Start / Stop Character

When generating a Codabar symbol one has to enter the start and stop character as ABC or D. This means that the stored item code of the database also contains these characters. To search for a received code requires that the scanner transmits these characters as well. For this reason this option of the scanner is switched on by reading the symbol

of Fig. 38.

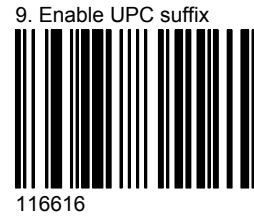

Fig. 39: Enable UPC Suffix

This will inform the scanner to send a suffix which informs the Barcode Reader Software which kind of UPC or EAN Symbol has been recognised.

By scanning the barcode of (Fig. 32) the scanner is switched back to its default settings. When the scanner is shipped it is already programmed and re-programming is only necessary once the scanner has been set back to its defaults. To enable the defaults of the scanner begin with the scanning of the “Recall Default Mode” label of Fig. 32. After that, scan the label from Fig. 33 to Fig. 39.

The system is shipped with a set of barcode label. The yellow ones are used for the above described procedure.

The power supply as well as the data transport is done through the interface cable. No dangerous electrical voltages are present within the scanner. Still, the power supply must be unplugged before taking off the cover of the bar code scanner. After this one should wait for 2 seconds till the rotating mirror arrangement (PGM) has come to a standstill.

A laser diode is used as a source of light, which emits a wavelength of 675 (±5) nm at a maximum power of 0.525 mW. The laser diode is equipped with a collimator that shapes the laser beam in such a way that within the working area of 165 mm, measured from the upper edge of the device, bands with minimum 13 mils (0.33 mm) and 7.5 mil at the upper edge (0.191 mm) can be read.

Based on the spectral data and the light power the scanner MS 7625 has been classified as the laser device of class I. The laser class does not get changed, when the upper part of the scanner is taken off. However, a constant looking at the laser beam must still be avoided.

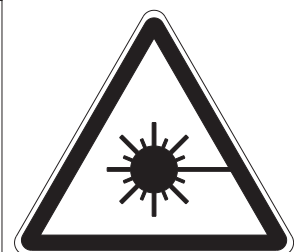
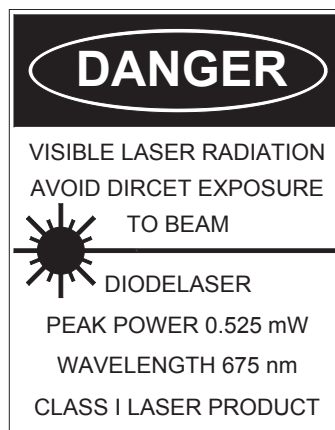

4.1.2 Scanner Interface ED-0270

This interface accomplishes three tasks:

1. Voltage supply for the Barcode Scanner
2. Data connection from the scanner to the PC
3. Buffering of the measurement signals from the scanner electronics

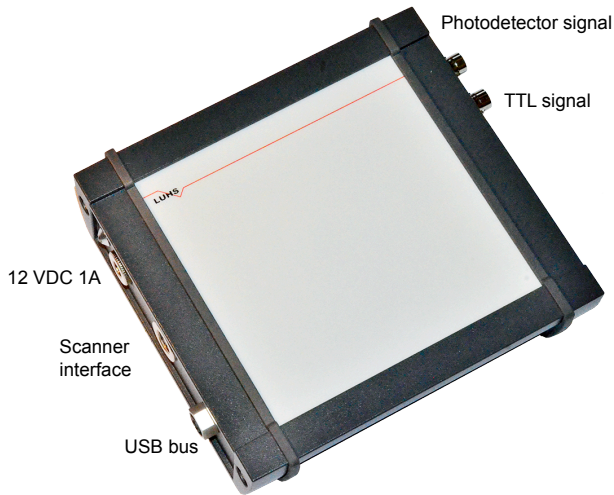

Fig. 40: Scanner Interface ED-0270

The barcode scanner is connected to the interface with the help of its cable. For this purpose, a multi-pin connector is present at the left side of the interface. Two BNC jackets are arranged at the opposite side, where the measurement signals of the scanner are available for displaying by means of an oscilloscope. One BNC jack provides the analogue AC signal of the photo detector of the scanner. The other one provides a signal, which is the digital TTL information of the analogue signal. The interface is connected to the USB port of the PC by means of the provided USB data cable. The scanner interface is powered by a 12VDC / 1A wall plug power supply.



Fig. 44: Set of configuration bar code symbol cards (left) and sample bar codes

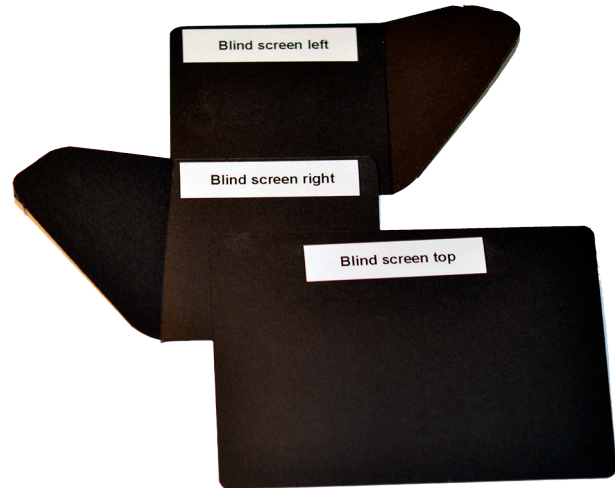

Fig. 45: Set of blind screens to cover the internal mirror or to block scan lines



Fig. 41: Interface (left) and USB cable (right)



Fig. 42: Mini BNC to regular BNC cable to connect the scanner signals from the interface to an oscilloscope



Fig. 43: Screw driver Torx T10 to remove the scanner top screws

5.0 Measurements

The measurements shown in this section are related to the detection of the light-dark transitions of a barcode symbol..

5.1 Preparing the Scanner

One would see a number of electrical signals, if one were to connect the signal of the photo detector of the barcode scanner to an oscilloscope and place a barcode symbol on the scanner. (Fig. 47).

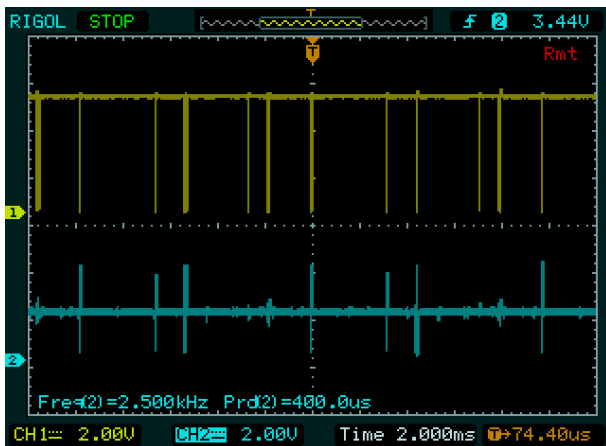

Fig. 46: Scanner signals due to the mirror edges

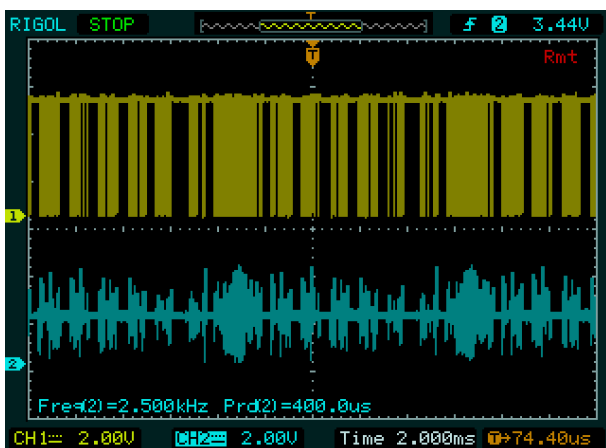

Fig. 47: Multiple signals make the interpretation difficult

The reason for this is that depending upon the position the barcode symbol on the scanner surface is read by different tracks (Fig. 29). Each of these tracks generates more or less a complete series of electrical signals. However, a reliable trigger signal cannot be recognized, so that one can identify a complete sequence on the oscilloscope as a standing picture. It is a good idea to reduce the number of laser tracks from 20 to one. To do this, we must cover four of the five deflecting mirrors within the scanner and then hide three more of the four remaining tracks by covering the scanner window. This requires an opening of the scanner and hence should be done by an experienced person.

Procedure:

- 1.0 The power supply of the Interface is disconnected. The next step is taken after about one minutes, after the rotating mirror has come to a standstill.
- 2.0 The top cover is lifted by hand from the scanner (Fig. 48).
- 3.0 Remove the four screws by using the provided torx (T10) screw driver (Fig. 49).

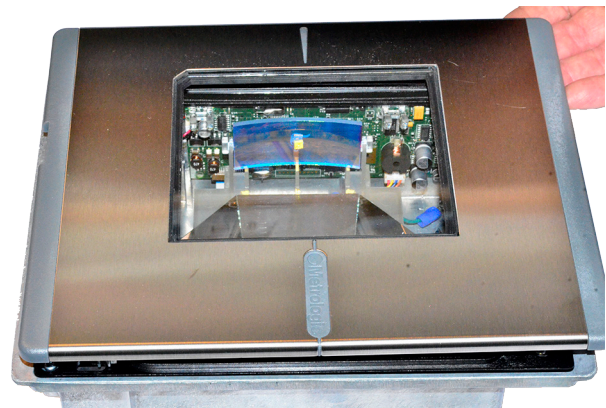

Fig. 48: Lift the top glass from the scanner



Fig. 49: Remove the screw of each corner

- 4.0 The plate is now lifted carefully by using the two attached plastic handles, since it is connected to the inside of the device with a connecting cable. Now the scanner is open and the entire scanner engine can be admired.(see Fig. 50).

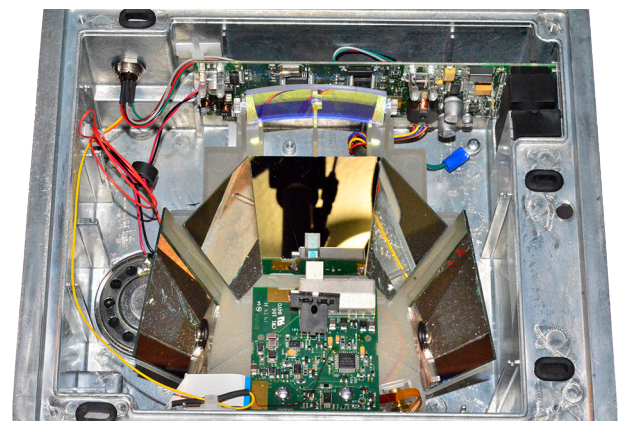

Fig. 50: Open bar code scanner

- 5.0 Both the provided black cover papers are placed in front of the mirrors (see Fig. 51).

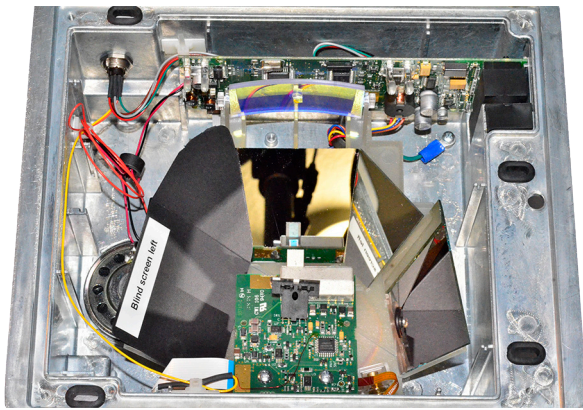

Fig. 51: Covering the two left mirrors

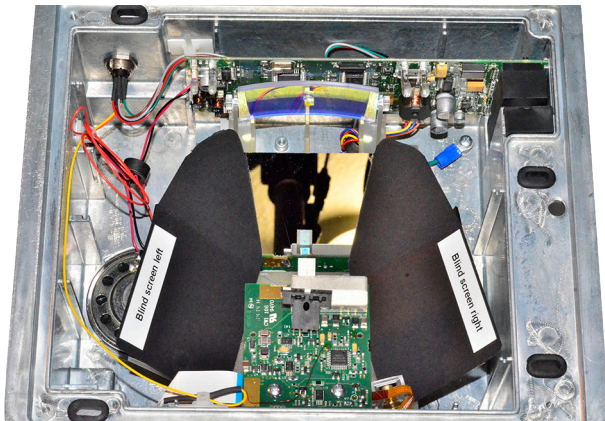

Fig. 52: Covering the remaining two mirror of the right side

1. The first cover, that one without fastening screws is set gently into the rubber slots. It completely covers the scanner.

The black paper (11.4 cm x 8 cm) is placed on top of the scanner window in such a way that three of the four tracks get covered and only one track remains.

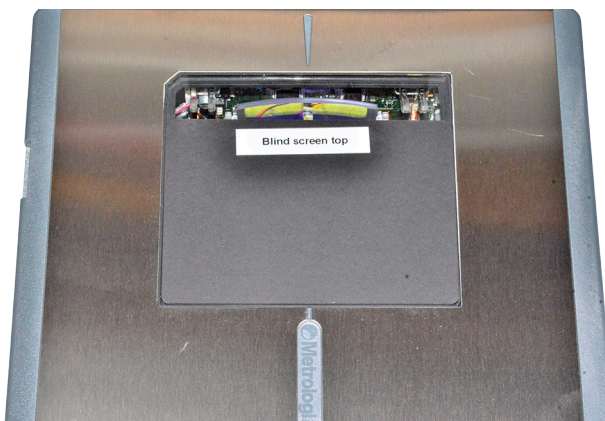

Fig. 53: Blind screen on top of scanner glass

To simplify further the interpretation of the electrical signals, one uses a symbol with bars as simple as possible.



Fig. 54: This symbol has been used for the following measurements

5.1.1 Photodetector Signals

After following these steps one can now clearly display the individual reading sequences. An example is shown in Fig. 55.

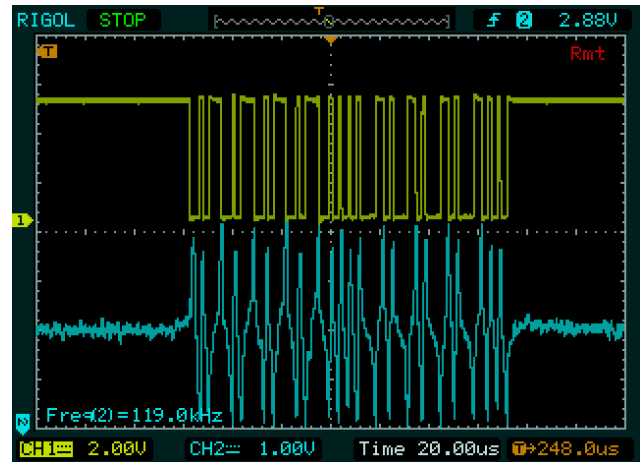

Fig. 55: Measuring the barcode signals, lower track is the analogue AC and the upper track TTL signals

The curves have been recorded with the help of a digital storage oscilloscope. The lower track shows the signal of the photodetector. It can be seen clearly, that the signal is AC coupled. This is the correct choice for the application, since one normally works with AC - signals to eliminate DC offsets from environmental light. The photo amplifier can hence be adapted optimally. One should consider, that these scanners have to be developed and manufactured at the lowest possible cost and the highest possible performance. A good example of this is the rotating mirror (MH). It is made of plastic material with a reflecting surface. The imaging properties are naturally not as good as those of a ground and polished glass mirror. However, to compensate for this, a photo detector with a larger sensor surface is used. This solution is much more economical and fulfils the same purpose.

The conformity to the used bar code sample can be seen clearly, it with the original symbol.

Test Symbol EAN8 0000 0000

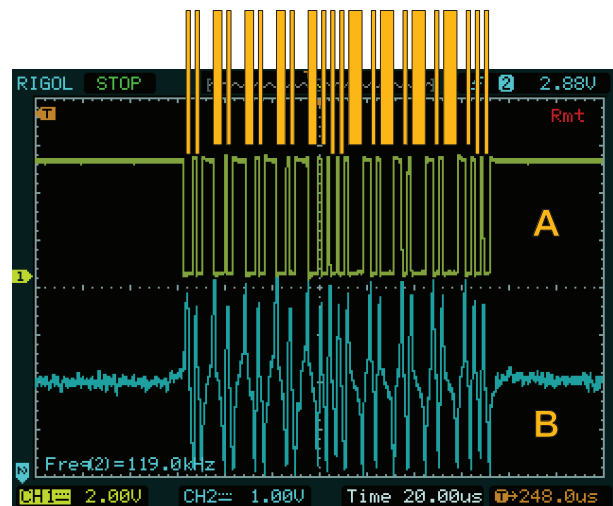

Fig. 56: Comparison of the original symbol with the measured electrical signal

Of course it must be like this, but one can note, that the scanning rate of the oscilloscope nearly reaches its limits. Due to the timing it becomes apparent here, that the scanner is working with a relatively high scan rate. From the measurement in Fig. 55 one can precisely determine the length of time of a scan over the EAN 8 symbol to $130 \mu\text{s}$. As has already been mentioned in section 2.3.1 the symbol comprises of 66 discrete bands. To resolve each band, the rise time must be clearly lower than $130 \mu\text{s} / 66 \approx 2 \mu\text{s}$.

We have used the symbol EAN 8 for the measurements. This symbol has a width of 20 mm including the quiet zones. To determine the speed of a laser point from the time measured for a symbol, we divide $20 \text{ mm} / 130 \mu\text{s}$. As such, the laser point has covered a distance of 0.020 m in $130 \cdot 10^{-6} \text{ s}$. This corresponds to a speed of 154 m/s or 554 km/h ! One can ask, why such high speeds have been selected. One can never be sure of an object at rest while reading the barcodes. This especially applies to the cash counters in supermarkets. For this reason the reading speed must be higher than that of the to be scanned product. Another requirement is to ensure the reading safety. To enable accuracy even in the case of damaged or disfigured symbols, many scans are evaluated statistically.

Another interesting measurement is the determination of the repetition rate.

5.1.2 Repetition rate

For this measurement one reduces the value of the time base of the oscilloscope for storing more than one reading event. To create a sharp reference we put a small sheet of white paper on top of the scanner.

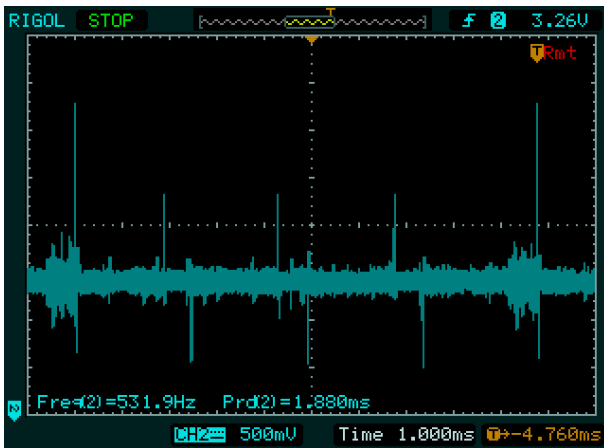

Fig. 57: Measuring the repetition rate

One takes 5 repetitions in a time period of about 45 msec from the Fig. 57. These values correspond to a duration of 9 msec, before the laser beam returns. This is done 111 times in one second. But since the total scan area consists of 20 tracks, it corresponds to a value of 2220 scan lines per second (!)

6.0 Software

6.1 Installing the software and related driver

6.1.1 USB driver

The required USB driver software is located in the folder “\Metrologic\USB Driver\” of the provided CD/DVD.

INSTALLATION: The driver can be installed to target computer by following one of the below methods:

6.0 Method 1 -- Install from a command prompt

- 6.1 Open a Command Prompt with “elevated privilege”. Right click “Start → All Programs → Accessories → Command Prompt” and Select “Run as administrator”.
- 6.1 Type cd <driver install directory>
- 6.1 Run setup.bat
- 6.1 Follow installation instructions.

7.0 Method 2 -- Install from Windows Explorer

(Note: This method recommended if the <driver install directory> is stored locally on target machine. Do not use this method if the <driver install directory> is stored in a network location)

- 7.1 Open the <driver install directory> with Windows Explorer.
- 7.1 Right click the file “setup.bat” and select “Run as administrator”
- 7.1 Follow installation instructions.

NOTES:

The Microsoft Visual C++ 2010 Redistributable Package may be required to be installed on target computer.

* 32 bit OS:
 <CD:>\Metrologic\USB Driver\C++ 2010 Redistributable Package\vc_redist_x86.exe

* 64 bit OS:
 <CD:>\Metrologic\USB Driver\C++ 2010 Redistributable Package\vc_redist_x64.exe

Connect the scanner to the interface (Fig. 40) and the USB cable from the interface to the computer. Power up by connecting the 12 VDC wall plug power supply to the interface. When the blue LED shows up, the power is provided correctly. Make sure that the bar code scanner is completely configured by reading the set of yellow bar code symbol cards, especially the “Enable USB” symbol card. The scanner will be recognized by the system and you will find an entry in the device manager like this one:

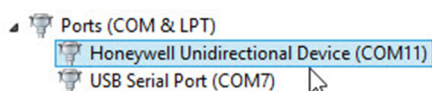

Note the comport number which is displayed in the parenthesis of the

“*Honeywell Unidirectional Device (COM xx)*”.

In this example the comport number is 11. This is needed to inform the Bar Code software via which port it will communicate with the bar code scanner.

6.2 Installing the Bar Code Software

The installation software can be found in the provided CD/DVD in the root folder:

setup.exe

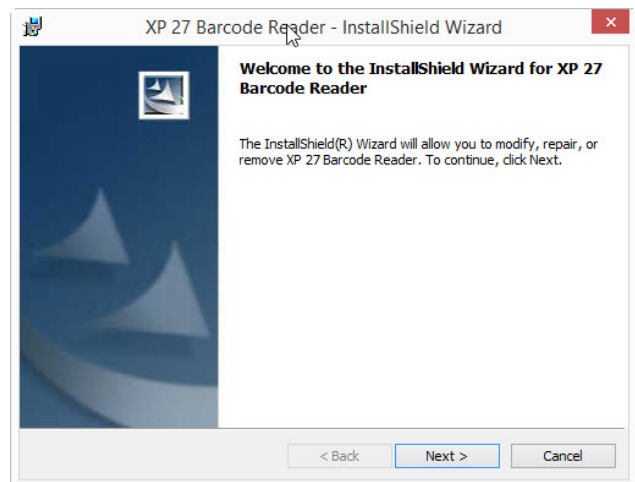

The installer launches, just follow the instructions. The software will be installed inside the following folder:

- 32 bit Windows C:\Program Files\EBEOS
- 64 bit Windows C:\Program Files (x86)\EBEOS

A shortcut is created on the desktop and within the program start group.

The Bar Code software fulfils three basic tasks:

1. Generation and management of a database, which contains data for the product.
2. Reading the data from the barcode scanner.
3. Printing the barcode labels

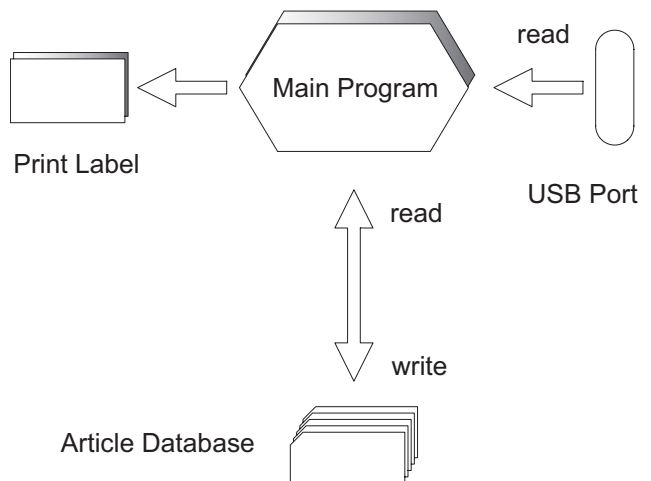

Fig. 58: Structure of the software “Barcode “

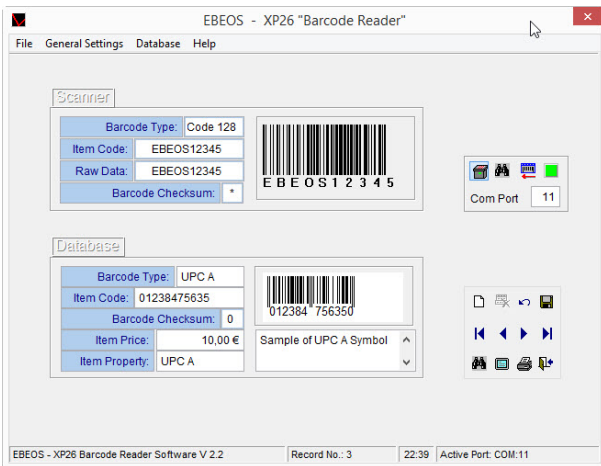

Fig. 59: Before connecting to the bar code scanner enter the port number into the ComPort field

The main program manages the article database, in which the data and the barcode symbols are saved and from which these can be retrieved. Symbols of the following types can be generated and read:

EAN 8	EAN 13	EAN 99
UPC E	UPC A	EAN 128
Code 39	Code 128	Codabar

The respective barcode symbols can be printed in different sizes (SC0 to SC2). The data read by the scanner can automatically be compared with the records saved in the database. In case a record is not available, the data read can be included in the database. The deletion of the complete database, as also of some selected records, is protected by password. The initial password is:

Default

and must be changed by the person in charge of this experiment.

6.2.1 Database

Field	Format	Description
Nummer	Character 24	Barcode number or character without the check number
Bild	Object	Barcode symbol object. This field is used for the printing
Descript	Memo	Detailed description of the article.
Property	Character 24	Additional features of the article.
DelFlag	Logical	This flag can only be modified by user entered records. Pre-installed records are marked with false and cannot be deleted.

Table 11: Structure of the Database “Barcode”

The field “Number” of the database Barcode contains the index number, which is used for searching an article quickly. The configurations are stored in another database “Settings”. The database contains two records, of which the first contains the default and the second, the user settings.

Field	Description
-------	-------------

BackColor	Background colour of the displayed and the printed barcode symbol. Default is white.
ForeColor	Foreground colour of the displayed and the printed barcode symbol. Default is black.
Font	Font type of the readable part of the barcode symbol. Default is Arial.
Bold	Makes the font “bold”. Default is false.
Italic	Makes the font appear in italics. Default is false.
Size	Size of the font. Default is 10 points.
PWD	Password. Default is “Default”.
ComPort	Number of the serial interface with which the PC is connected to the Barcode Scanner. Default is 2.

Table 12: Structure of the Database “Settings”

The databases can be saved by the normal “copy” command of the operating system. After a regular installation, the databases are present in the directory:

32 bit Windows C:\Program Files\EBEOS\Data
 64 bit Windows C:\Program Files (x86)\EBEOS\Data
 as:

File name	Meaning
Barcode.dbf	Main table containing the records
Barcode.cdx	Index file containing the references to the records with the help of the Index numbers.
Barcode.fpt	Memo file, contains the contents of the field “Object” with a reference to the corresponding record in the main data table.
Barcode.tbk	Backup copy of the memo file
Settings.dbf	Data table for the configuration

All these files must be saved for a complete backup.

6.2.2 Program Menus

The operation and the description of the software are present in the software itself and can be viewed with the help of the help functions.

Menu	Submenu 1	Submenu 2	Description
File	Print Label		Printing of Barcode Labels
	Close		Close the program
General Settings	Barcode Fonts		Setting the fonts of the readable part of the barcode
	Barcode Color	Background	Background colour of the barcode symbol
		Foreground	Foreground colour of the barcode symbol
	Default Values		Sets all the values to default
Barcode Scanner	Read Data	ON	Activates the data reception to the scanner
		OFF	Deactivates the data reception to the scanner
	Select Comport	COM 1	Selects the serial interface COM1
		COM 2	Selects the serial interface COM2
Database	Browse		Shows the complete database in a window
	Set Database Order TO	Barcode Item	Sorts according to barcode information
		None	Sorts according to record number
	Clean up		Final removal of records marked for deletion
	Delete all Records		Deletes all records that are not protected
Help	What is this ?		Context sensitive help
	Barcode Reader Help		Calls the Help

Table 13: Overview of Menu structure

6.2.3 Generation of Barcodes

For creating the barcodes one selects the desired type of the barcode and enters the desired text in the input field. In case the type and the number of characters do not conform to the type, a message and a valid suggestion is shown. If the selected barcode type supports a check number, the program calculates it automatically and inserts it. Further help is provided in the help file of the barcode program.

6.2.4 Reading the Barcodes

For this purpose one selects the following option from the menu:

Barcode Scanner → Read Data → ON

The software is now ready to receive the data from the scanner. As soon as the scanner recognises a valid symbol, it sends the information to the selected serial interface, from where it is received by the software. The symbol read as well as the contents are displayed in a window on the screen. If the automatic data search is activated, the system searches for a matching record as soon as it receives the information. If the record exists, it is shown in the database window. Otherwise the data can be stored in the database, if desired.

6.2.5 Printing the Barcode Labels

The program permits the printing of a selected symbol or the complete database. One can select the predefined sizes of SC0 to SC2 for the symbols EAN 13/8 and UPC A/E. The print menu is present under the menu:

File → Print Label

6.2.6 Changing the Password

Changing the password select:

Database → Delete all Records

A dialog box appears in which one is requested to enter the password. The password "Default" applies to the first call. One can enter a new password in the dialog that follows.



WWW.LD-DIDACTIC.COM



LD DIDACTIC distributes
its products and solutions
under the brand LEYBOLD

LEYBOLD®